

**RODIX INCORPORATED**  
2303 23rd Ave, Rockford IL 61104  
TOLL FREE (800) 562-1868, FAX (815) 316-4701  
E-mail [custserve@rodix.com](mailto:custserve@rodix.com)  
[www.rodix.com](http://www.rodix.com)

**FEEDER CUBE®**  
**CE-43 *Plus* ALL PURPOSE**  
**OIL RESISTANT MODEL**  
**IMPORTANT: APPLICATION NOTE**



**Replacement Parts:**

<u>Designation</u>	<u>Quantity</u>	<u>Item</u>	<u>Characteristics</u>	<u>Rodix P/N</u>	<u>Manufacturer P/N</u>
Control Card	(quan. 2)		120V	Rodix No. 24-488*	
Fuse	(quan. 1)		15 A, 250V	Rodix No. 106-18*	Littlefuse 314015
Fuse	(quan. 1)		5 A, 250V	Rodix No. 106-21*	Littlefuse 314005
Fuse Holder	(quan. 2)			Rodix No. 106-17	Littlefuse 354901GY
Triac	(quan. 2)			Rodix No. 115-32*	
S1	(quan. 2)		DPST	Rodix No. 104-80*	
Switch Boot	(quan. 2)			Rodix No. 104-26*	
Terminal, Single, End			20A, 600V	Rodix No. 264-301	Wago 264-301
Terminals, Single			20A, 600V	Rodix No. 264-321	Wago 264-321
Terminals, Dual			20A, 600V	Rodix No. 264-351	Wago 264-351
Knob				Rodix No. 122-10	APEM 42011-3B-1/4

\*Recommended spare parts to keep in stock.

If troubleshooting assistance is needed, either visit our web site at [www.rodix.com](http://www.rodix.com), call RODIX: (international call) 815-316-4700x22 or (USA) 1-800-562-1868x22, FAX: 815-316-4701, or e-mail: [custserve@rodix.com](mailto:custserve@rodix.com).

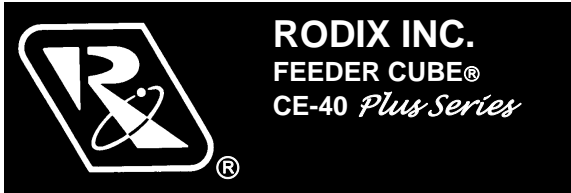

## CE-43 Plus

P/N 121-500-0748

### PRODUCT DESCRIPTION

This device, P/N 121-500-0748, is used to control the vibration levels of two vibratory feeder devices. Normally, Unit-A controls a feeder bowl, Unit-B controls either a vibratory inline or hopper. The units are powered from the incoming line connection. Each unit has its own Master Control PC board. The setup and operation is detailed in the following product literature.

### SPECIFICATIONS

Line Voltage:	120 VAC +/-10%
Line Frequency:	50/60 Hz
Current:	20A (Unit-A: 15A; Unit-B: 5A)
Output Voltage:	0-120 VAC)
Handling & Transp. Temp.	-40 – 60 °C
Operating Temp.	0 – 40 °C

### INSTALLATION

The control is to be firmly mounted to a non-vibrating surface. The control is designed to withstand conditions equal to IP54. Do not install the control in a more severe environment. Connections to external conduits or cords are to be made with hardware that is rated at IP54 or better.

Refer to the electrical wiring diagram. Line and load wiring is to be brought into the box via customer-drilled holes. Use 2.5mm<sup>2</sup> (#12 AWG) Mains supply wires or larger. For Unit A and B load wires, use 2.5mm<sup>2</sup> (#14 AWG) or larger. The

Mains supply wires should be fused by the Customer at 20 amps or less. After the wiring has been completed, verify the continuity of the ground bond connection to the control.

This control is for industrial use. Use in residential areas may cause interference, and in that case, special measures may have to be taken by the user regarding emissions.

### SAFETY

When installing this control, a power supply disconnect device must be provided by the user.

A power plug/socket combination can be utilized for this purpose. The plug and socket must have a breaking capacity of at least the amperage of the vibratory feeder(s).

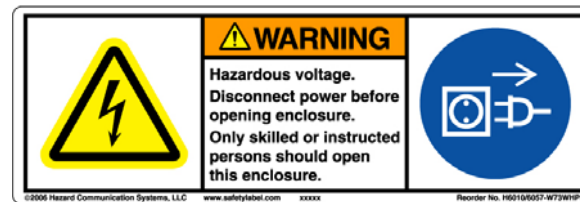

Figure 1 – Warning label installed on the control

**Warning – There is hazardous voltage inside the control. Disconnect power before opening the enclosure.** Only skilled or instructed persons should open the enclosure.

An electrically instructed person is a person adequately advised or supervised by an electrically skilled person to enable him or her to perceive risks and to avoid hazards which electricity can create.

An Emergency stop device must be installed on the machine that incorporates the CE feeder control.

When the machine is installed, verify the continuity of the protective bonding circuit (earth ground) to the control.

### PERIODIC INSPECTION AND FUNCTIONAL TESTING

When the control is operating normally, the output can be smoothly adjusted from zero to maximum by the main control knob. If soft-start is used, the output should start at zero and ramp up to the desired setting each time the control automatically starts.

The control should be kept reasonably free from dirt and contaminants that might inhibit proper cooling. No other planned maintenance is necessary.

### Maintenance

Normally no maintenance is needed for this control. If troubleshooting assistance is needed, either visit our web site at [www.rodix.com](http://www.rodix.com), call RODIX: (international call) 815-316-4700x22 or (USA) 1-800-562-1868x22, FAX: 815-316-4701, or e-mail: [custserve@rodix.com](mailto:custserve@rodix.com).

© 2000, 2006 RODIX INC.

CE-43 Plus 060918.doc

# ADJUSTMENT AND SET UP UNITS A & B

**Warning – There is hazardous voltage inside the control. Disconnect power before opening the enclosure. Only skilled or instructed persons should open the enclosure.**

## 1. SELECTING 60 OR 120 PULSE OPERATION

- A. For 60 pulse output - Set switch (S1) to 60 on "master control" P.C. card (No. 24-488).
- B. For 120 pulse output - Set switch (S1) to 120 on "master control" P.C. card.

**Note: Readjust MAX pot after changing pulse switch setting.**

## 2. LIMITING THE MAXIMUM OUTPUT OF CONTROL

Adjust the **MAX** Output trimpot so that the output to the feeder reaches its desired maximum level when the **MAIN CONTROL DIAL** is turned fully clockwise. The **MAX** Output trimpot should be adjusted to keep the vibratory feeder from hammering when the control is turned up to full power.

**NOTE: Output to feeder must be connected and the control set for proper output frequency (60 or 120 pulse) setting. The Run Jumper must be connected as shown on the wiring diagram.**

- A. The power input should be **OFF** or disconnected and the cover should be closed.
- B. Rotate the **MAIN CONTROL DIAL** on front cover to 0.
- C. Using **CAUTION**, turn power **ON**.
- D. Rotate the **MAIN CONTROL DIAL** on front cover slowly to the desired feed rate. If

hammering occurs decrease the **MAIN CONTROL DIAL** setting.

- E. Disconnect power to the control and open cover to allow access to printed circuit card.
- F. Adjust the **MAX** Output trimpot so that the output to the feeder reaches its desired maximum level when the **MAIN CONTROL DIAL** is turned fully clockwise. Turning the **MAX** Output trimpot clockwise increases the maximum output level. Adjust the **MAX** Output trimpot in small increments. Repeat steps B-F as required.

## 3. REMOTE OFF/ON CONTROL

Note: a Run Jumper has been installed at the factory as shown on the enclosed wiring diagram.

Remote OFF/ON operation of the CE-40 *Plus Series* Feeder Cube® control can be configured to operate in one of the following ways.

- A. A low current switch such as a paddle switch can replace the factory-installed Run jumper. The "Run Contact" connects across the Direct and Return terminals. The contact must be able to switch 5VDC and 2mA. The control will then run only when the contact is closed. Refer to Section A of the OFF/ON CONTROL GUIDE.

- B. Feeder Bowl/Hopper Interlock allows the Hopper control to operate only when the Bowl is running and the paddle switch contact is closed. The **interlock input** on terminals 11 and 12 of TB2 is controlled by the **interlock output** of a "Parts Sensing Feeder Bowl Control" such as a CE-90 *Plus*

Remove the "Run" jumper of this control from across the Direct and Return terminals. Connect the Hopper Paddle switch to the Interlock and Return terminals. Connect TB2 terminals 11 and 12 of this control to the "Parts Sensing Control". Refer to Section B of the OFF/ON CONTROL GUIDE. Check specific instructions for the "Parts Sensing

Control" wiring.

Note: Only use the Bowl/Hopper Interlock with a CE-90 and CE-40 *Plus* Series control. Two CE-40 Series controls will not interlock to each other since neither one has an **interlock output**.

- C. Low Voltage DC can be used to turn the control **ON** and **OFF**. Move the Run Jumper to the Interlock and Return terminals. Connect a +5 to 30VDC (10mA) signal to terminal 12 and the reference (GND) to terminal 11 of TB2. The control will now turn **ON** when the DC signal is present at terminals 11 and 12 of TB2. This input is optically isolated. Refer to Section C of the OFF/ON CONTROL GUIDE.
- D. AC Voltage may be used to turn the control **ON** and **OFF**. This requires a 105-250VAC signal, with 2mA leakage maximum. Set up the control by moving the Run Jumper to the Interlock and Return terminals. Connect the 105-250VAC Signal to terminal 12 (L1) and the common (L2) to terminal 10 of TB2. The control will now turn **ON** whenever the AC signal is applied to terminals 10 and 12 of TB2. This input is optically isolated. Refer to Section D of the OFF/ON CONTROL GUIDE.

TB-2 terminals 5-7 are transformer isolated from the line voltage circuit.

## 4. MAIN CONTROL DIAL

The output power is controlled by the **MAIN CONTROL DIAL**. A special logarithmic-tapered power out curve (non-linear) spreads the power broadly across the **MAIN CONTROL DIAL** to help give maximum "Fine Control" over the output speed of the vibratory feeder.

## 5. SETTING THE SOFT-START

The start-up of the control output can be adjusted to ramp up to the desired output level instead of starting abruptly. This keeps parts from falling off the tooling of a vibratory feeder when it turns on; it can reduce hammering during turn on; it can also simulate a paddle switch ON delay. Adjust the **SOFT Start** trimpot clockwise for the gentlest start (about a 10-second ramp up to full output). Turn the trimpot fully counter-clockwise for no soft start.

## **6. LINE VOLTAGE COMPENSATION**

Fluctuations in the line Voltage can cause a feeder bowl to vary its feed rate. The line voltage compensation feature adjusts the control's output to help compensate for fluctuations in the supply voltage. If it becomes necessary to disable this feature, remove resistor R4 from the bottom of the board with a pair of pliers, twist R4 to snap it off.

## **7. REMOTE SPEED CONTROL**

Remote control of the power signal level can be accomplished by the following methods:

- A. 4-20mA signal from a PLC can be used to remotely vary the output of the control instead of the Main Control Dial. This feature is automatically turned on whenever a 4-20mA signal is applied to the control. To return control to the Main Control Dial, remove the 4-20mA signal by turning it off or use a switch to open the circuit. The 4-20mA input is transformer isolated from the power line.
- B. 0-5VDC Analog input signal may be applied in place of the Main Control Dial. For further information, contact RODIX.
- C. Remote control of the output power level can be accomplished by using an optional **Step Up/Down Remote Speed Interface P/N 123-148**.

## **CAUTION:**

**Fuses should be replaced with Littelfuse 3AB "Fast Acting" type or equivalent of manufacturer's original value.**

**Mounting this control on a vibrating surface will void the warranty.**

## **WARRANTY**

**Rodix Control Products are Warranted to be free from defects in material and workmanship under normal use for a period of two years from date of shipment.** For the full description of the warranty, terms, and software license, please contact the factory.

For assistance installing or operating your Rodix Feeder Cube® please call the factory or visit our web site. Technical help is available to answer your questions and fax any needed information. To return a control for IN or OUT of warranty service, please ship it prepaid to:

**Rodix Inc., ATTN: Repair Department**

If under warranty, Rodix will repair or replace your control at no charge; If out of warranty, we will repair it and you will be billed for the repair charges (Time and Material) plus the return freight. Quotes for repairs are available upon request. A brief note describing the symptoms helps our technicians address the issue.

Feeder Cube® is a registered TM of Rodix Inc.

Banner® is a registered Trademark of Banner Engineering Corp.

## **DIMENSIONS**

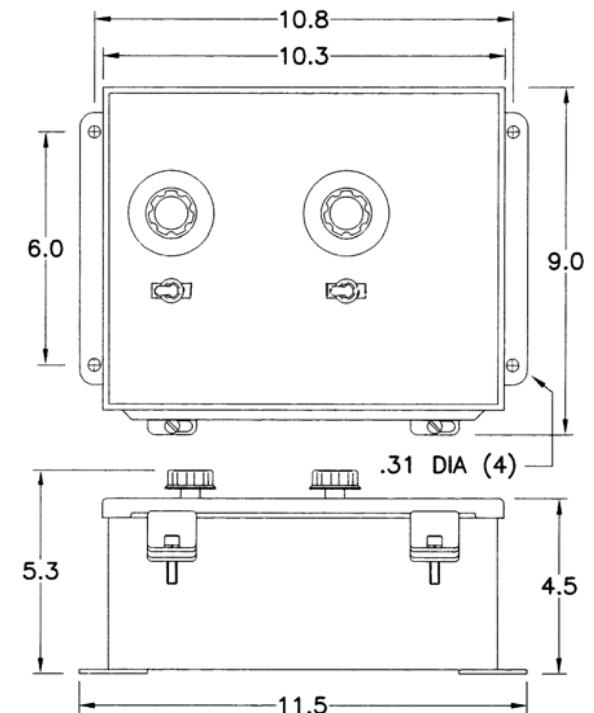

## **RODIX, INC.**

2303 23rd Ave, Rockford, IL 61104  
Toll Free (800) 562-1868, FAX (815) 316-4701  
E-mail [custserve@rodix.com](mailto:custserve@rodix.com)  
[www.rodix.com](http://www.rodix.com)



## RODIX SOLUTION

### Good wiring practices for avoiding electrical noise problems.

Rodix controls have been designed with a high degree of immunity to electrical noise; however, depending on the control installation, electrical noise can cause problems. These problems occur in less than 1% of the product installations. Most electrical noise problems can be avoided by following some simple guidelines. Good wiring practices need to be used to prevent electrical noise from interfering with your control's operation. Another name for electrical noise is Electro-Magnetic Interference (EMI).

#### Symptoms of Electrical Noise

The symptoms of electrical noise would appear as follows: a brief pause or a brief "bump" in the vibratory feeder's output that the control automatically recovers from. In rare cases the control will either stop operating or run continuously at full power in 120 pulse mode until the power switch is slowly cycled OFF and ON.

#### Sources of Electrical Noise

Electrical noise is generated by devices like relay coils, solenoid valves, contactors, servo motors, and variable

frequency inverter drives. The electrical noise is then transferred to another device by one of three ways. The noise could be conducted through the power wires, or capacitively coupled from wire to adjacent wire, or it is transmitted from the wires of a noise source.

#### Solutions for Electrical Noise

1. Use shielded wires for all I/O (Input / Output) signals. The I/O signals may include: 4-20mA input, Run input, Sensor input, 0-5VDC input, Interlock input or AUX output. The shield "drain" wire should be tied to the chassis in the Rodix control. The drain wire should be kept shorter than 2". Please see the enclosed picture.

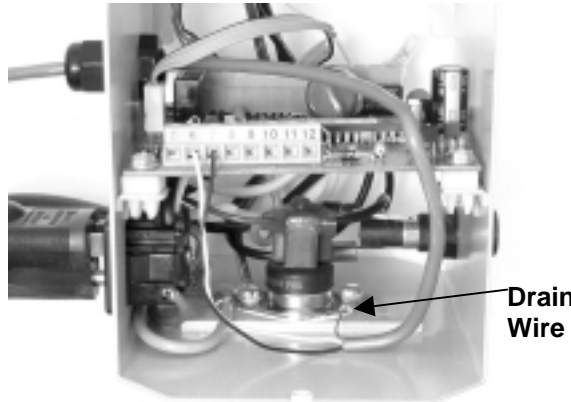

Example of a "drain" wire termination

2. Never run I/O signal wires in the same conduit or raceway as AC power lines such as wires to motors, solenoids, heaters, welders and Rodix controls, etc.

3. I/O wires within an enclosure should be routed as far away as possible from relays, solenoids, transformers, power wiring and other noisy equipment. Keep the I/O signal wires separate from the control's input and output power wiring. Secure the wires in place.

4. Whenever relays or solenoid valves are used, install a Snubber on them to reduce electrical noise. Use a diode on a DC coil. Use a RC Snubber on an AC coil.

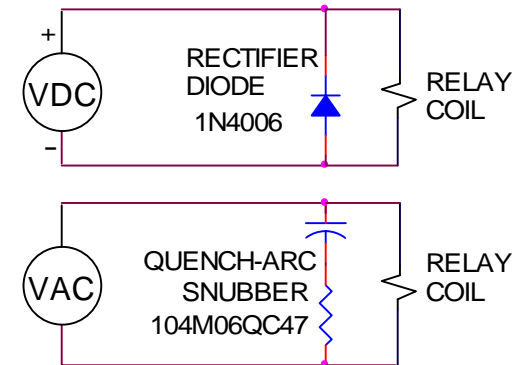

5. In extremely high EMI environments, Power Line Filters and ferrite beads can be effective. Install ferrite beads on I/O signal wires as close as possible to the circuit board terminal strip. Loop the wire through the bead several times or use several beads on each wire for additional protection.

### **RODIX, INC.**

2303 23rd Ave. Rockford, IL 61104  
 Toll Free (800) 562-1868, FAX (815) 316-4701  
 E-mail [custserve@rodix.com](mailto:custserve@rodix.com)  
[www.rodix.com](http://www.rodix.com)

# Declaration of Incorporation

We hereby declare that the following machinery is intended to be incorporated into other machinery, and must not be put into service until the relevant machinery into which it is to be incorporated has been declared in conformity with the essential requirements of the Machinery Directive, 89/392/EEC, and requirements of the Low Voltage Directive, 2006/95/EC.

## **BS EN 61326-1 Electrical equipment for measurement, control and laboratory use – EMC requirements**

When using electrical equipment for control use, BS EN 61326-1 supercedes Electromagnetic Emissions EN 50081-2 and Electromagnetic Immunity EN 50082-2.

**Safety of Machinery:** EN 60204-1: 2006

**Supplementary Information:** Machine Safety Report Number – 98021628.J02  
Machine Safety testing performed by:  
Intertek Testing Services, 7435 4th Street North, Oakdale, MN 55128

EMC testing was performed by Rodix at:  
L.F. Research, 12790 Route 76, Poplar Grove, IL 61065

**Machine Description:** Vibratory Feeder Control

**Makes:** CE-41 Plus, CE-41H Plus, CE-43 Plus, CE-43H Plus, CE-48 Plus, CE-48H Plus, CE-49 Plus, CE-49H Plus, CE-91 Plus, CE-91H Plus, CE-91-2 Plus, CE-91-2H Plus, CE-91-3 Plus, CE-91-3H Plus, CE-93 Plus, CE-93H Plus, CE-98 Plus, CE-98H Plus, CE-98-2 Plus, CE-98-2H Plus, CE-98-3 Plus, CE-98-3H Plus, CE-99 Plus, CE-99H, CE-101 Plus, CE-101H Plus, CE-103 Plus, CE-103H Plus, CE-108 Plus, CE-108H Plus, CE-109 Plus, CE-109H Plus, CE-113 Plus, CE-113H Plus, CE-119 Plus, CE-119H Plus, and SPE-606.

**Types:**

121-500-0606  
121-500-0700 through 121-500-0703  
121-500-0706 through 121-500-0721  
121-500-0724 through 121-500-0736  
121-500-0738 through 121-500-0780

**Manufactured by:** Rodix, Inc.

A technical construction file for this equipment is retained at the following address:

**2303 23rd Avenue, Rockford, Illinois 61104-7370**

**Date:** 2/19/2008  
**Title:** Vice President

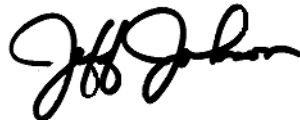
**Signature:**   
**Name:** Jeff Johnson

# RODIX Inc.

## CE restrictions for harmonic current emissions

Revised 5/3/2006

For vibratory feeder controls that have the CE mark, one of the many standards that the control needs to conform to is "Limits for harmonic current emission". The machine configuration will determine when to apply this standard.

### **International Standard IEC 61000-3-2** Effective 1/1/2001

Limits – Limits for harmonic current emissions (equipment input current  $\leq$  16A per phase)

This part of IEC 61000 deals with the limitation of harmonic currents injected into the public low-voltage distribution system (electric utility). If the equipment input current exceeds 16A per phase, please refer to IEC 61000-3-4.

Harmonic currents can cause stress to the utility distribution system. It can stress the neutral of older wiring that doesn't conform to today's standards, and it can stress the utility transformers that are operating at their rated load.

### **When the standard does not apply:**

This standard doesn't apply if the 230V machine is powered by a step down transformer.

The scope of the standard states:

IEC 61000-3-2 is applicable to electrical and electronic equipment having an input current up to and including 16A per phase, and intended to be connected to public low-voltage distribution systems.

Public low-voltage distribution systems are power supply systems allowing the direct connection of equipment with rated voltages between 200 and 260V (single phase) or between 340 and 450V (phase to phase). Higher voltage distribution systems, which are connected to power substations, are not considered to be public low-voltage systems.

A 230V machine with a vibratory feeder is typically powered by a step down transformer that is installed in a factory. Thus the machine is powered by a higher voltage distribution system that is not directly connected to the 230V public low-voltage system. Because of this, the machine is outside the scope of the standard<sup>1</sup>.

### **When the standard does apply:**

When a 230V machine is not powered by a step down transformer, there should not be a problem meeting this standard if all the vibratory feeders on one machine operate in the 100 Pulse (full wave) mode, and the combined total amperage for the vibratory feeders is 15 Amps or less. However it is harder to meet this standard in the 50 Pulse (half wave) mode. The combined total amperage for the vibratory feeders is limited to 3.5 Amps in the 50 Pulse mode when the machine is powered directly from the 230V public low voltage distribution system.

The vendor that supplies the finished machine is responsible for compliance to the applicable CE standards, not the end user. This vendor is responsible for performing the compliance testing on the finished machine.

Please note that EN61000-3-2 applies to 230V equipment. There are no limits for 120V equipment since these limits have not yet been defined; however, in Europe the 120V equipment will be connected to a step down transformer that might connect to the public 230V power mains. This means that 120V equipment that does not meet the harmonic current standard may cause a step down transformer that connects to the public 230V to fail to meet the harmonics standard.

### **50/100 Pulse – Alternate names:**

The frequency of the utility power is 50Hz in Europe and 60Hz in the United States. Because of this, 50 Pulse mode in Europe is related to 60 pulse mode in the United States. 100 Pulse mode in Europe is related to 120 pulse mode in the United States. To change the pulse mode on the control, change the 60/120 switch. Listed below are some of the alternate names used to describe 60 pulse and 120 pulse:

<u>60 Pulses Per Sec.</u>	<u>120 Pulses Per Sec.</u>
R.C. or D.C.	A.C.
Rectified	Full Wave AC
Direct Current	Alternating Current
Half Wave	Full Wave
3600 Vibrations Per Min.	7200 Vibrations Per Min.

<sup>1</sup> From TUV Rheinland, FAQ

[http://www.tuv.com/en/services/product\\_testing/all\\_types\\_of\\_products/electromagnetic\\_compatibility\\_services\\_emc/emc\\_faq.php](http://www.tuv.com/en/services/product_testing/all_types_of_products/electromagnetic_compatibility_services_emc/emc_faq.php)

# RODIX Inc.

## CE notes about voltage fluctuations and flicker

### **What you need to know about the CE voltage fluctuations and flicker standard:**

For machines that have the CE mark, one of the many standards that machine must conform to is the Limitation of voltage fluctuations and flicker. The machine configuration will determine when to apply this standard.

### **International Standard IEC 61000-3-3** Effective 1/1/2001

“Limits – Limitation of voltage fluctuations and flicker in low-voltage supply systems for equipment with rated current  $\leq 16$  amps per phase.” This part of IEC 61000 deals with the limitation of voltage fluctuations and flicker injected into the public low-voltage supply system (electric utility). When the amperage is over 16 amps, a companion standard, IEC 6100-3-11 is applied.

The limits in this standard are based mainly on the subjective severity of how much a 230V/60 W light bulb flickers when the supply voltage fluctuates. The frequent flickering of a light bulb can adversely affect some people.

### **When the standard does not apply:**

This standard doesn't apply if the 230V machine is powered by a step down transformer.

The scope of the standard states:

IEC 61000-3-3 is applicable to electrical and electronic equipment having an input current up to and including 16A per phase, and intended to be connected to public low-voltage distribution systems of between 220V and 250V at 50Hz line to neutral.

Public low-voltage distribution systems are power supply systems allowing the direct connection of equipment with rated voltages between 200 and 260V (single phase) or between 340 and 450V (phase to phase). Higher voltage distribution systems, which are connected to power substations, are not considered to be public low-voltage systems.

A 230V machine with a vibratory feeder is typically powered by a step down transformer that is installed in a factory. Thus the machine is powered by a higher voltage distribution system that is not directly connected to the 230V public low-voltage system. Because of this, the machine is outside the scope of the standard<sup>1</sup>. A machine that is connected to 60Hz power is also outside the scope of the standard.

### **When the standard does apply:**

The standard is applicable when a 230V machine is powered directly from the 230V public low-voltage supply system.

The vendor that supplies the finished machine is responsible for compliance to the applicable CE standards, not the end user. This vendor is responsible for performing the compliance testing on the finished machine.

Please note that EN61000-3-3 applies to 230V equipment. There are no limits for 120V equipment since these limits have not yet been defined; however, in Europe the 120V equipment will be connected to a step down transformer that might connect to the public 230V power mains. This means that 120V equipment that does not meet the standard may cause a step down transformer that connects to the public 230V to fail to meet the standard.

### **What causes voltage fluctuations:**

When an electrical load is turned on, it can cause the supply voltage to decrease a little bit due to the resistance and the inductance of the supply wires and step down transformer. The addition of a larger amp load causes a larger change to the supply voltage than a small amp load does. When the load turns off, the supply voltage rebounds back to the original value.

### **Disclaimer:**

Standard EN61000-3-3 applies to the vibratory feeder system, and it does not apply to the vibratory feeder control. The amount of voltage fluctuations and flicker depends on how often the electrical load is turned On and Off by the machine and how large the load is.

---

<sup>1</sup> From TUV Rheinland, FAQ

[http://www.jp.n.tuv.com/en/services/product\\_testing/all\\_types\\_of\\_products/electromagnetic\\_compatibility\\_services\\_emc/emc\\_faq.php](http://www.jp.n.tuv.com/en/services/product_testing/all_types_of_products/electromagnetic_compatibility_services_emc/emc_faq.php)

## CE notes about voltage fluctuations and flicker continued

### Guideline chart:

The chart provided here is not a substitute for a test. It is meant only to help determine when further review of standard EN61000-3-3 is needed. The chart does not cover every circumstance. Please note: if the machine is rated at 120 volts, or 60 Hz, this standard does not apply.

To use this chart, determine how many amps the machine uses during its normal operation. Is the amperage over 16 amps? Determine the amperage of the vibratory feeder when the feeder bowl (or hopper) is operating at its maximum feed rate with a full load of parts. Determine how often the vibratory feeder typically turns on and off. Compare the amps and on/off cycles to the chart.

For multiple vibratory feeders only add their amperage together if they always start and stop at the same time. Actual testing may prove that the number of On/Off cycles shown in the chart can nearly be doubled when the Soft Start pot is adjusted for a one second (or longer) soft start.

Amps rms at 230V	Maximum On/Off cycles permitted
16	1 On/Off cycle per 6 minutes
15	1 On/Off cycle per 4.5 minutes
14	1 On/Off cycle per 3 minutes
13	1 On/Off cycle per 3 minutes
12	1 On/Off cycle per 3 minutes
11	1 On/Off cycle per 3 minutes
10	1 On/Off cycle per 1.5 minutes
9	1 On/Off cycle per 1 minute
8	1 On/Off cycle per 1 minute
7	1 1/3 On/Off cycles per 1 minute
6	2 On/Off cycles per 1 minute
5	6.5 On/Off cycles per 1 minute
4	19 On/Off cycles per 1 minute
3	65 On/Off cycles per 1 minute
2	195 On/Off cycles per 1 minute
1	Unlimited On/Off cycles per 1 minute

This chart is based on Rectangular voltage changes at equal intervals using the Pst=1 chart, fig. 4 of standard EN61000-3-3.  $Plt = Pst \times 0.65$

120 VAC 50/60 Hz  
HOT COM PE

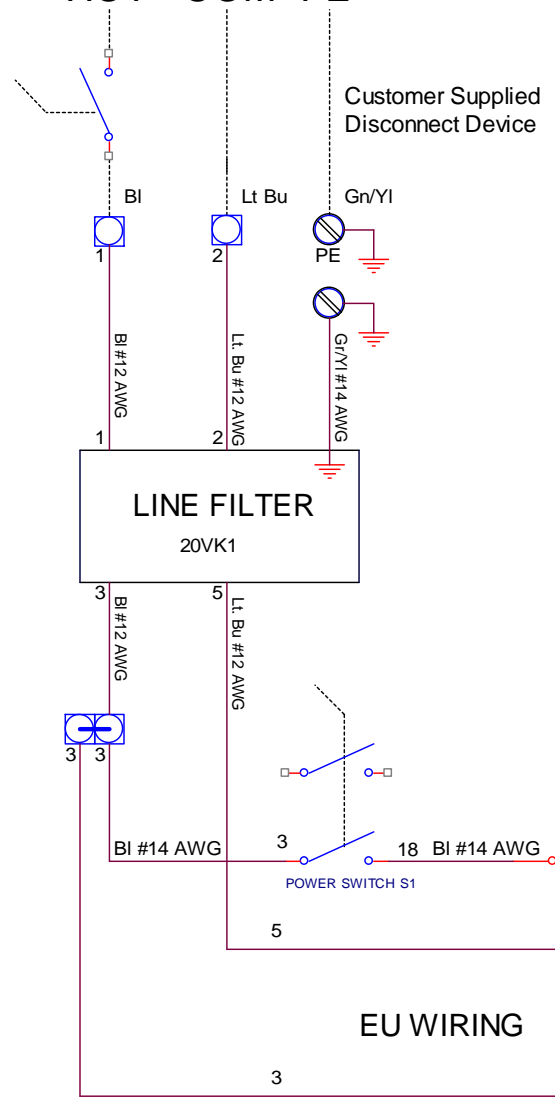

EU WIRING

### FC-40-PLC PLUS OFF/ON CONTROL GUIDE

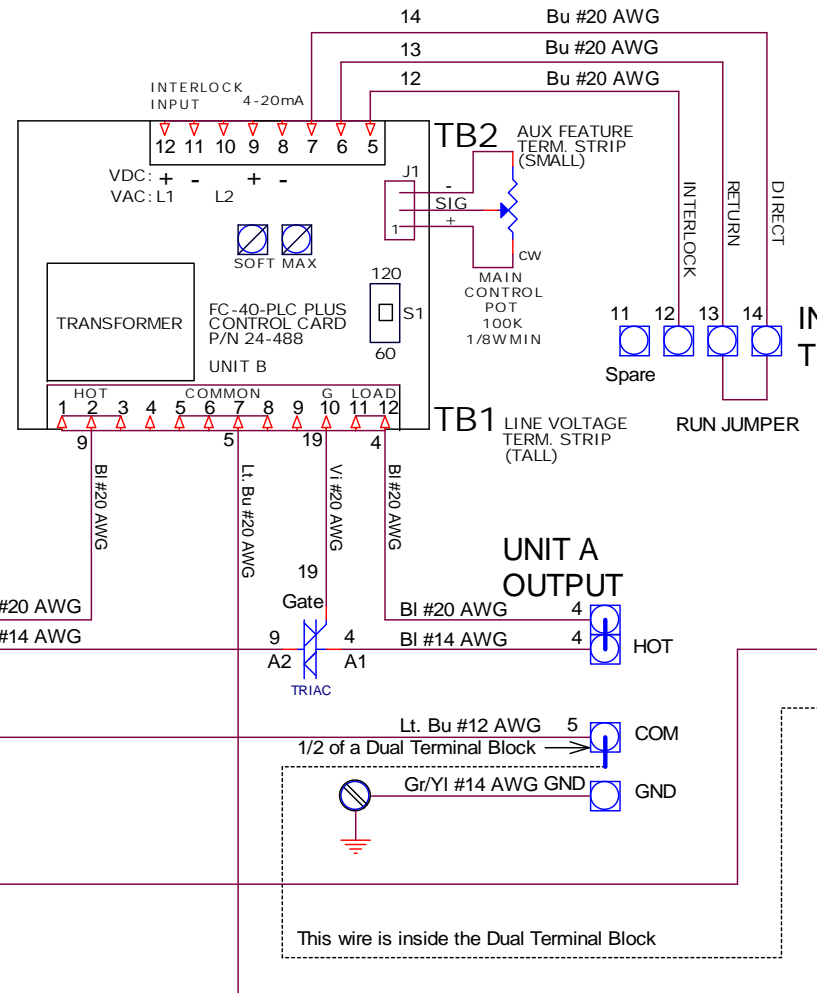
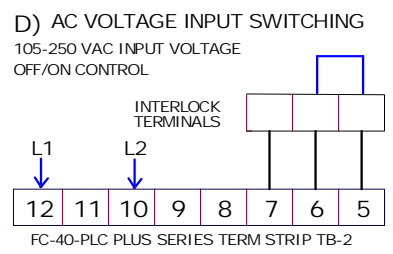
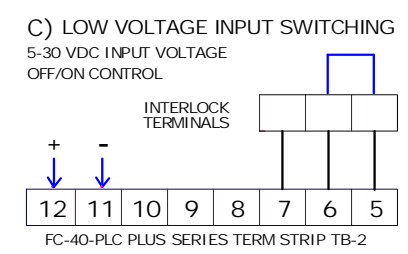
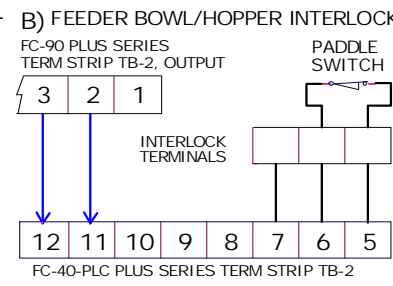
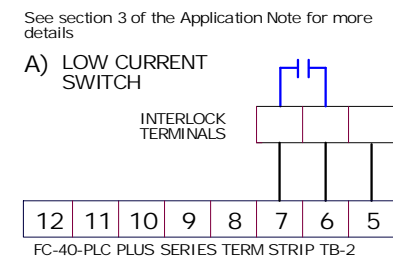

UNIT A  
OUTPUT

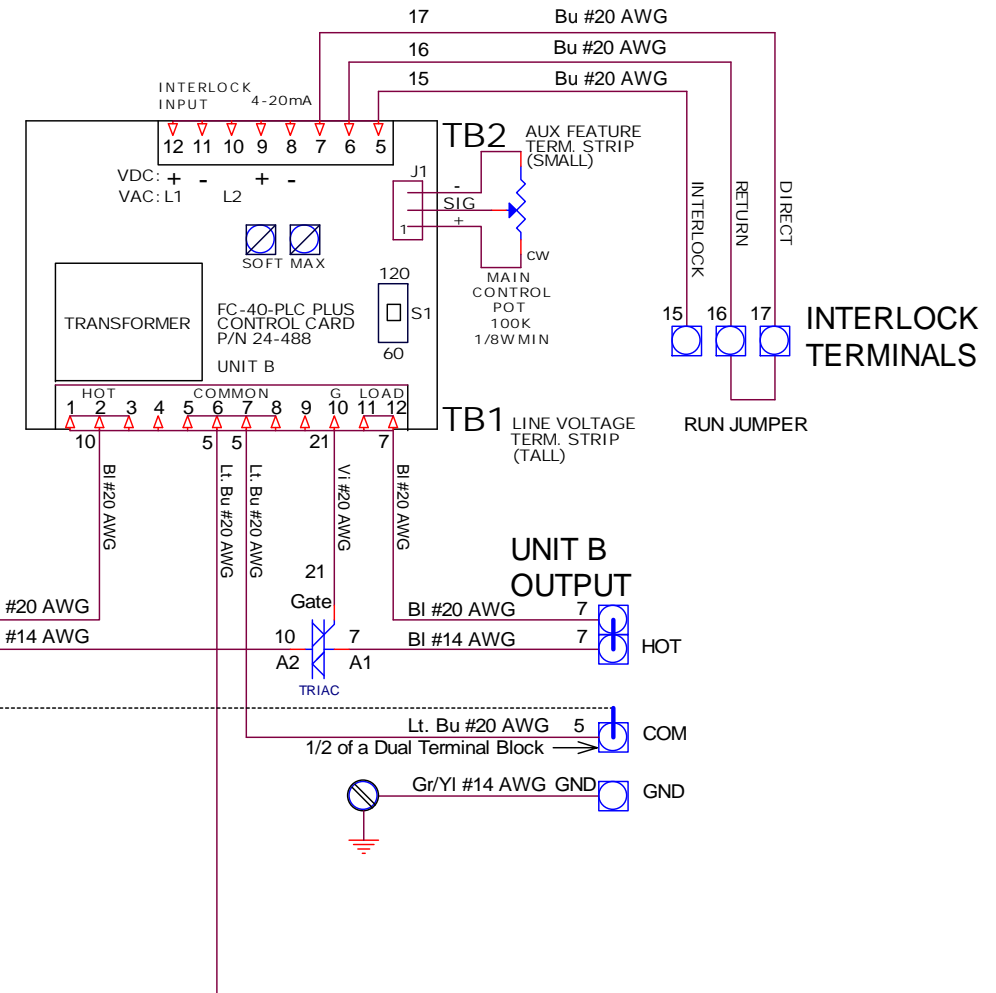

UNIT B  
OUTPUT

Caution: Disconnect power before opening enclosure

Installation instructions:  
When installing this control, a power supply disconnect device must be provided by the user. A power plug/socket combination can be utilized for this purpose. The plug and socket must have a breaking capacity of at least the amperage of the vibratory feeder(s).

The size of the Mains supply wires should be 2.5mm<sup>2</sup> (#12 AWG) or larger.  
The Mains supply wires should be fused by the Customer at 20 amps or less.

### TRIAC REFERENCE GUIDE

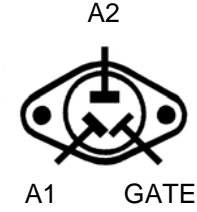

**CE** **CE-43 PLUS**  
**P/N 121-500-0748**  
2/9/09 © 2000, 2006 RODIX INC.  
**RODIX INCORPORATED**  
2303 23rd Ave, Rockford IL 61104  
TOLL FREE (800) 562-1868, FAX (815) 316-4701  
E-mail [custserve@rodix.com](mailto:custserve@rodix.com)  
[www.rodix.com](http://www.rodix.com)